

Instruction Manual

Tektronix

TCP202

15 Ampere AC/DC Current Probe

070-9542-01

Copyright © Tektronix, Inc. All rights reserved.

Tektronix products are covered by U.S. and foreign patents, issued and pending. Information in this publication supercedes that in all previously published material. Specifications and price change privileges reserved.

Tektronix, Inc., P.O. Box 500, Beaverton, OR 97077

TEKTRONIX and TEK are registered trademarks of Tektronix, Inc.

WARRANTY

Tektronix warrants that the products that it manufactures and sells will be free from defects in materials and workmanship for a period of one (1) year from the date of purchase from an authorized Tektronix distributor. If any such product proves defective during this warranty period, Tektronix, at its option, either will repair the defective product without charge for parts and labor, or will provide a replacement in exchange for the defective product. Batteries are excluded from this warranty.

In order to obtain service under this warranty, Customer must notify Tektronix of the defect before the expiration of the warranty period and make suitable arrangements for the performance of service. Customer shall be responsible for packaging and shipping the defective product to the service center designated by Tektronix, shipping charges prepaid, and with a copy of customer proof of purchase. Tektronix shall pay for the return of the product to Customer if the shipment is to a location within the country in which the Tektronix service center is located. Customer shall be responsible for paying all shipping charges, duties, taxes, and any other charges for products returned to any other locations.

This warranty shall not apply to any defect, failure or damage caused by improper use or improper or inadequate maintenance and care. Tektronix shall not be obligated to furnish service under this warranty a) to repair damage resulting from attempts by personnel other than Tektronix representatives to install, repair or service the product; b) to repair damage resulting from improper use or connection to incompatible equipment; c) to repair any damage or malfunction caused by the use of non-Tektronix supplies; or d) to service a product that has been modified or integrated with other products when the effect of such modification or integration increases the time or difficulty of servicing the product.

THIS WARRANTY IS GIVEN BY TEKTRONIX WITH RESPECT TO THE LISTED PRODUCTS IN LIEU OF ANY OTHER WARRANTIES, EXPRESS OR IMPLIED. TEKTRONIX AND ITS VENDORS DISCLAIM ANY IMPLIED WARRANTIES OF MERCHANTABILITY OR FITNESS FOR A PARTICULAR PURPOSE. TEKTRONIX' RESPONSIBILITY TO REPAIR OR REPLACE DEFECTIVE PRODUCTS IS THE SOLE AND EXCLUSIVE REMEDY PROVIDED TO THE CUSTOMER FOR BREACH OF THIS WARRANTY. TEKTRONIX AND ITS VENDORS WILL NOT BE LIABLE FOR ANY INDIRECT, SPECIAL, INCIDENTAL, OR CONSEQUENTIAL DAMAGES IRRESPECTIVE OF WHETHER TEKTRONIX OR THE VENDOR HAS ADVANCE NOTICE OF THE POSSIBILITY OF SUCH DAMAGES.

Contacting Tektronix

Phone	1-800-833-9200*
Address	Tektronix, Inc. Department or name (if known) 14200 SW Karl Braun Drive P.O. Box 500 Beaverton, OR 97077 USA
Web site	www.tektronix.com
Sales support	1-800-833-9200, select option 1*
Service support	1-800-833-9200, select option 2*
Technical support	Email: techsupport@tektronix.com 1-800-833-9200, select option 3* 6:00 a.m. - 5:00 p.m. Pacific time

* **This phone number is toll free in North America. After office hours, please leave a voice mail message. Outside North America, contact a Tektronix sales office or distributor; see the Tektronix web site for a list of offices.**

Table of Contents

General Safety Summary	iii
Getting Started	1
Features and Accessories	1
Installation	3
Compensating the Probe (Optional)	4
Operating Basics	5
Measurement Limits	5
Degaussing and Balancing the Probe	6
Measurement Procedures and Techniques	7
Reference	13
Power Measurements	13
Inductance Measurements	14
Continuity Test of Multiple-Conductor Cable	18
Measuring Inductor Turns Count	18
Specifications	20
Warranted Characteristics	20
Typical Characteristics	22
Nominal Characteristics	27
Maintenance	29
Cleaning the Probe Head	29
Servicing the Compensation Box	30
Probe Head Disassembly	34
Obtaining Replacement Parts	38
Preparation for Shipment	39
Performance Verification and Adjustment	40
Test Procedure Conditions	40
Equipment Required	40
DC Accuracy	41
Bandwidth	42
Rise Time	42
Calibrator Accuracy (Optional)	43
Replaceable Parts	44
Parts Ordering Information	46
Using the Replaceable Parts List	46

List of Figures

Figure 1: TCP202 Current Probe	1
Figure 2: Coarse Balance Adjustment	3
Figure 3: Connecting the Calibrator	4
Figure 4: Polarity of Current Flow	8
Figure 5: Measuring Differential Current and Nulls	9
Figure 6: Increasing the DC Measurement Range	11
Figure 7: Increasing Probe Sensitivity	12
Figure 8: Measuring Inductance with a Low-Impedance Source	15
Figure 9: Linear Current versus Time Ramp	16
Figure 10: Measuring Inductance with a High-Impedance Source	17
Figure 11: High-Impedance Source Current Ramp	17
Figure 12: Measuring the Number of Turns in a Coil	19
Figure 13: Turns Measurement Using Reference Coil	19
Figure 14: Frequency Derating	23
Figure 15: Insertion Impedance - Magnitude - Single Conductor	23
Figure 16: Insertion Impedance - Phase Angle - Single Conductor	24
Figure 17: Insertion Impedance - Magnitude - 10-Turn #24 AWG Primary	25
Figure 18: Insertion Impedance - Phase Angle - 10-Turn #24 AWG Primary	26
Figure 19: Current Ratings	27
Figure 20: Replacing TekProbe Interface Pins	30
Figure 21: Replacing the TekProbe collar	31
Figure 22: Removing the Compensation Box Covers	32
Figure 23: Accessing the Gain Adjustment	33
Figure 24: Replacing the Compensation Box Cover	34
Figure 25: Removing the Strain Relief Boot	35
Figure 26: Removing the Top Half of the Probe	36
Figure 27: Removing the Probe Slide	37
Figure 28: Removing the Current Transformer	38
Figure 29: TCP202 and Replaceable Accessories	46
Figure 30: Replaceable Parts - Compensation Box	48
Figure 31: TCP202 Optional Accessories	50

General Safety Summary

Review the following safety precautions to avoid injury and prevent damage to this product or any products connected to it.

Injury Precautions

Do Not Operate in Wet/Damp Conditions. To avoid electric shock, do not operate this product in wet or damp conditions.

Do Not Operate in an Explosive Atmosphere. To avoid injury or fire hazard, do not operate this product in an explosive atmosphere.

Observe Maximum Working Voltage. Do not use this product on bare wires above 300 V (DC + peak AC).

Product Damage Precautions

Do Not Drop the Probe Head. The probe head contains fragile components that can be damaged by a high impact. Take care to prevent the probe head from dropping on the floor or other hard surface. Secure the probe head in a safe location when not in use.

Do Not Operate With Suspected Failures. If you suspect there is damage to this product, have it inspected by qualified service personnel.

Do Not Immerse in Liquids. Clean the probe using only a damp cloth. Refer to cleaning instructions.

Safety Terms and Symbols

Terms in This Manual. These terms may appear in this manual:



WARNING. *Warning statements identify conditions or practices that could result in injury or loss of life.*



CAUTION. *Caution statements identify conditions or practices that could result in damage to this product or other property.*

Terms on the Product. These terms may appear on the product:

DANGER indicates an injury hazard immediately accessible as you read the marking.

WARNING indicates an injury hazard not immediately accessible as you read the marking.

CAUTION indicates a hazard to property including the product.

Symbols on the Product. These symbols may appear on the product:



CAUTION
Refer to Manual



WARNING
High Voltage



Double
Insulated



Protective Ground
(Earth) Terminal



Do not connect to or
remove from an
uninsulated conductor that
is **HAZARDOUS LIVE**.



Breakable.
Do not drop.



Use only on an
insulated wire.

Certifications and Compliances

Refer to the specifications section for a listing of certifications and compliances that apply to this product.

Getting Started

This section describes the TCP202 Current Probe and gives instructions on how to install and functionally test the probe.

Features and Accessories

The TCP202 Current Probe (Figure 1) is a 50 MHz current probe for use with Tektronix oscilloscopes that have the TekProbe interface. The probe can measure up to 15 A (DC + peak AC).

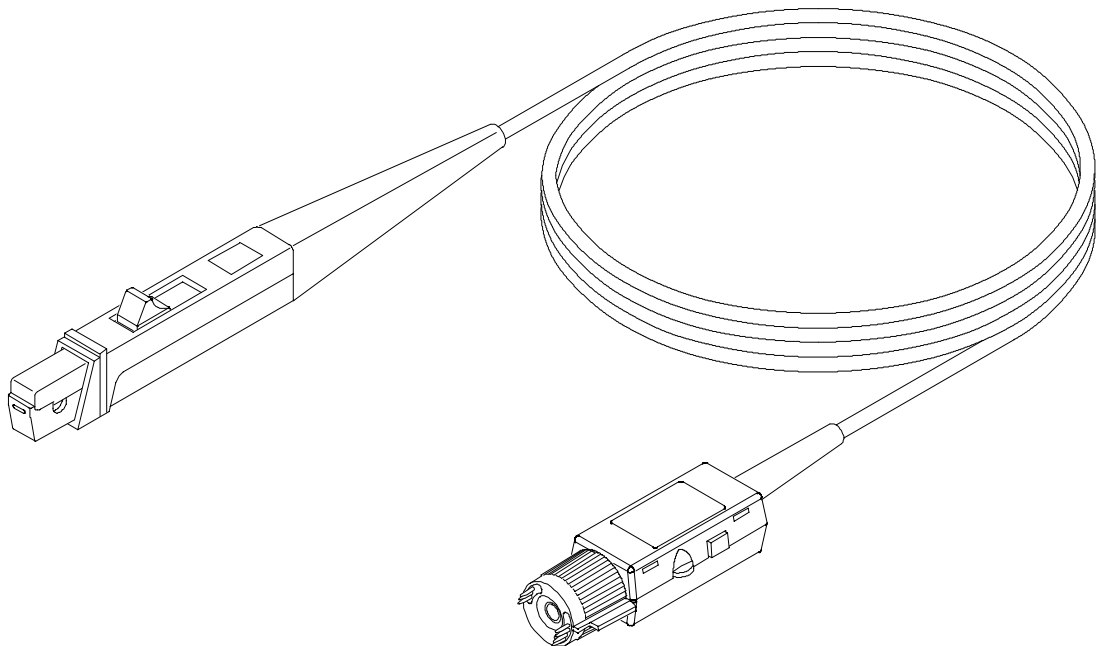
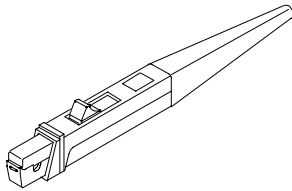
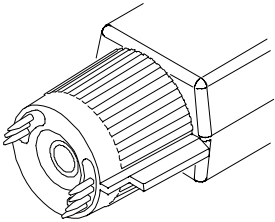

Figure 1: TCP202 Current Probe



Probe Head. The probe head contains a Hall Effect device for measuring current. The jaw of the probe clamps on any wire (including insulation) that is less than or equal to 3.8 mm (0.15 inches) in diameter.



TekProbe Interface. The TekProbe interface provides power, signal, and probe characteristic data.

If your oscilloscope does not support the TekProbe interface, you can use the optional 1103 probe power supply as an effective interface. Contact your local Tektronix representative for more information.

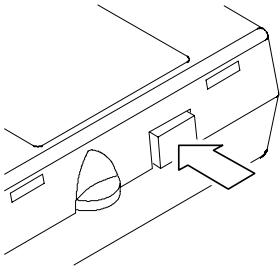

Degauss. The degauss button removes residual magnetism from the probe core that would otherwise cause measurement errors.

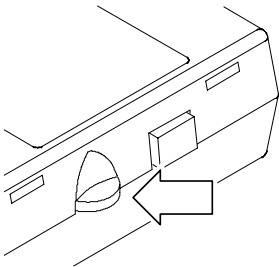

Balance Thumbwheel. The balance thumbwheel compensates for minor DC offsets of the probe output.

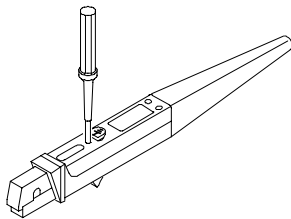

Coarse Balance Adjustment. The coarse balance adjustment centers the range of the balance thumbwheel. Use this adjustment only if the thumbwheel does not have enough range.

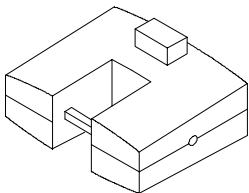

Calibrator (optional). With some TDS oscilloscopes, you can compensate the probe for maximum accuracy using the optional calibrator. Use the calibrator only if your oscilloscope displays the $A\Omega$ symbol when the current probe is connected. (For ordering information, see *Replaceable Parts* starting on page 44.)

Installation

Install the TCP202 Current Probe as follows:

1. Set the input channel to a zero reference point.
2. Connect the output of the probe to the TekProbe interface of the oscilloscope or other measurement instrument. The measurement instrument input must have a ground reference.

If your TDS oscilloscope does not display amperes/division, interpret volts/division as amperes/division.

If you are using the 1103 TekProbe Power Supply, you must set the oscilloscope input coupling to DC and the input impedance to 50 Ω . Interpret V/division as 10 A/division. For example, interpret 100 mV/division as 1 A/division.

3. With the probe jaw empty, push the slide on the probe until it locks in the CLOSED position.
4. Press the DEGAUSS button.
5. Balance the probe as follows:
 - a. Set the oscilloscope vertical scale to 10 mA/division.
 - b. Open and close the probe jaw.
 - c. Adjust the BALANCE thumbwheel until the displayed signal is zero.
6. If you cannot zero the display as described in step 5c, use the coarse balance adjustment (Figure 2) to center the range of the thumbwheel.

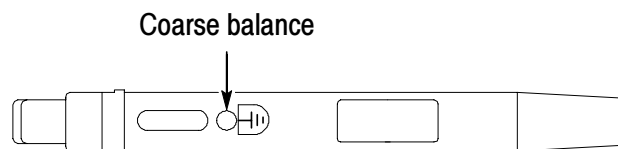

Figure 2: Coarse Balance Adjustment

Compensating the Probe (Optional)

With some TDS oscilloscopes, you can compensate the probe for maximum accuracy using the optional calibrator. Perform this procedure only if your oscilloscope displays the $A\Omega$ symbol when you connect the probe output to the oscilloscope input.

1. To connect the calibrator, press the release button (Figure 3) and connect the calibrator to the probe compensation output of the oscilloscope.

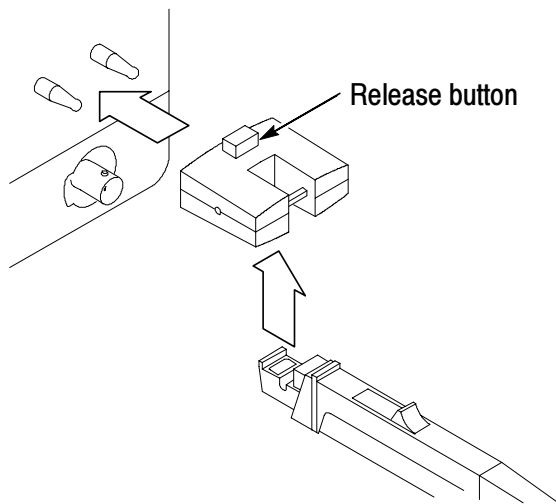

Figure 3: Connecting the Calibrator

2. Close and lock the probe jaw over the calibrator loop.
3. Adjust the oscilloscope to display the signal.
4. Press VERTICAL MENU→Cal Probe→OK Compensate Gain.

If the probe passes the compensation routine, the probe is accurate to within $\pm 1\%$ from 50 mA to 5 A and $\pm 2\%$ from 5 A to 15 A.

If the probe fails the compensation routine, refer to the procedure for checking the DC accuracy of the probe on page 41 and the procedure for accessing the internal gain adjustment on page 32.

Repeat this procedure whenever you move the current probe to another input.

Operating Basics

This section contains important precautions and techniques for clamping the probe on a circuit and taking basic measurements.

Measurement Limits

Before you clamp the probe on a circuit to measure current, observe the precautions for uninsulated wires and the maximum current ratings.

Precautions for Uninsulated Conductors



WARNING. *To avoid electrical shock from uninsulated conductors, observe the following precautions:*

Disconnect the power to the uninsulated conductor before inserting the conductor in or removing the conductor from the probe jaw.

Do not apply a voltage higher than 300 V (DC + peak AC) between earth ground and an uninsulated conductor that is in the probe jaw.

Maximum Current Rating

There are two basic current ratings: maximum *peak* current and maximum *continuous* current. In addition, the maximum peak current is limited by the A/second rating. For a graph of these limits, refer to Figure 19 on page 27.

The maximum peak current is 50 A with a pulse width $\leq 10 \mu\text{s}$ (500 μA seconds). This 500 μA seconds rating applies to any peak current over 15 A. The product of the peak current and pulse width (at 50% of peak) must be 500 μA seconds or less. For example, the maximum pulse width is 20 μs for a pulse of 25 A peak.

The maximum continuous current that this probe can measure is 15 A (DC + peak AC). This limit derates with frequency; as the frequency increases, the maximum current rating decreases. For a graph of this relationship, see Figure 14 on page 23.

Multiple Current Probes

Up to four TCP202 current probes may be used simultaneously on one TDS Series oscilloscope if the total in-phase current measured by all of the probes does not exceed 40 amperes. Above 40 amperes, the TekProbe interface may overload and cause measurement or display errors.

When one or two TCP202 current probes are used on a TDS Series oscilloscope, the ratings are as shown in Figure 19 on page 27.

Degaussing and Balancing the Probe

For accurate measurements, you must occasionally degauss and balance the probe. Degaussing removes residual magnetization from the probe core that would otherwise shift the zero point and cause measurement errors. Balancing the probe compensates for any DC offset that remains on the probe output after degaussing.

Degauss and balance your probe in each of the following cases:

- After turning on the oscilloscope and allowing a 20-minute warm-up period
- Whenever an overload condition occurs
- Whenever the probe is subjected to a strong external magnetic field
- Whenever there is a measurable DC offset that does not come from the conductor under test

To degauss and balance the probe, follow the installation procedure on page 3.

You may degauss the probe with a conductor in the jaw if you first disconnect the power to the conductor. This technique compensates for any offsets caused by stray DC magnetic fields around the circuit under test.



CAUTION. *While degauss occurs, the probe will induce a small voltage in the unpowered circuit (33 mV in series with 1.5 M Ω). Your circuit must be able to absorb this induced voltage. With low impedance circuits, several amperes may be induced in the circuit being measured. This may be of concern if you are using very small conductors.*

Measurement Procedures and Techniques

This section presents procedures and techniques for basic current measurements.

Basic Procedure

Measure AC or DC current in a single conductor as follows:

1. Observe the safety precautions and operating limits.
2. If necessary, degauss and balance the probe.
3. Close and lock the probe jaw over the conductor. Conventional current flows from positive to negative. For the correct polarity reading, connect the probe so that the current flow, from positive to negative, is aligned with the arrow on the probe jaw (see Figure 4).
4. Read the measurement. Adjust the display of the measurement instrument as necessary.
5. If necessary, adjust the oscilloscope offset control to offset a DC level. (AC coupling is automatically disabled on TDS oscilloscopes when the probe is connected.)

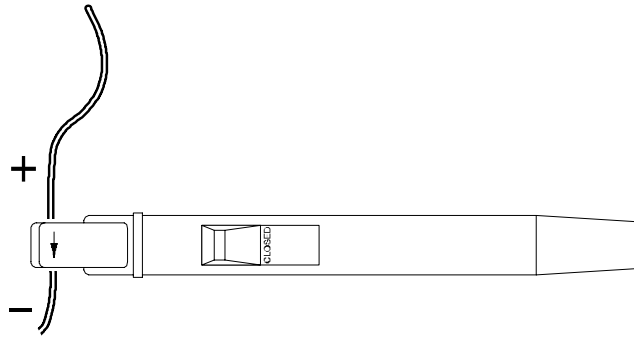

Figure 4: Polarity of Current Flow

Measuring Differential Current

You can place two conductors in a current probe to provide a differential or null current measurement. This avoids the necessity of using two current measurement systems with a differential oscilloscope amplifier.

1. Orient the two conductors under test so that the polarities oppose each other. Clamp the current probe around the two conductors as shown in Figure 5.
2. Measure the current. A waveform above the baseline indicates the conductor with the conventional current flow in the direction of the probe arrow is carrying the greater current.
3. To adjust for a current null, adjust the current in one of the conductors until the displayed measurement is zero.

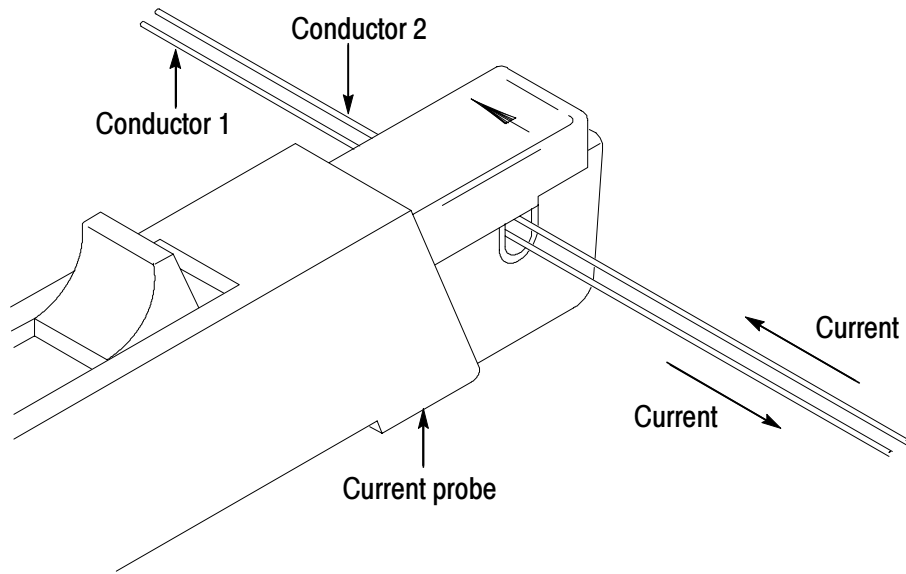

Figure 5: Measuring Differential Current and Nulls

Extending the DC Current Range

You may encounter situations where your measurement exceeds the maximum current rating of the connected probe. This section discusses methods for extending DC current ranges without exceeding specified limits.



WARNING. *To avoid personal injury or equipment damage, do not exceed the specified electrical limits of the oscilloscope or any applicable accessories. When using multiple conductors, do not exceed current limits on either conductor.*

If you want to measure a low-amplitude AC component that is superimposed on an extremely large steady state DC component (such as in a power supply), or if you want to extend the DC current range of your probe, you can add offset (bucking) current with a second conductor.

By adding bucking current, the amount of DC current that you measure is the difference between the DC component of the signal and the bucking current. You can then calculate the amount of DC current in the conductor under test by adding the value of the measured current to the value of the bucking current.

To supply additional bucking current, place a second conductor that has a pure DC component of known value in the probe jaw with the conductor under test, as shown in Figure 6(a) on page 11. Orient the second conductor so that the bucking current flows in the opposite direction of the DC flow in the conductor under test.

You can increase the value of the bucking current by winding multiple turns of the second conductor around the probe, as shown in Figure 6(b) on page 11. The bucking current is equal to the current flowing in the conductor, multiplied by the number of turns wound around the probe. For example, if the second conductor has a current of 100 mA DC and is wrapped around the probe five times, the DC bucking current is 100 mA multiplied by 5, or 500 mA DC.

NOTE. Adding a second conductor to the probe reduces the upper bandwidth limit of the probe.

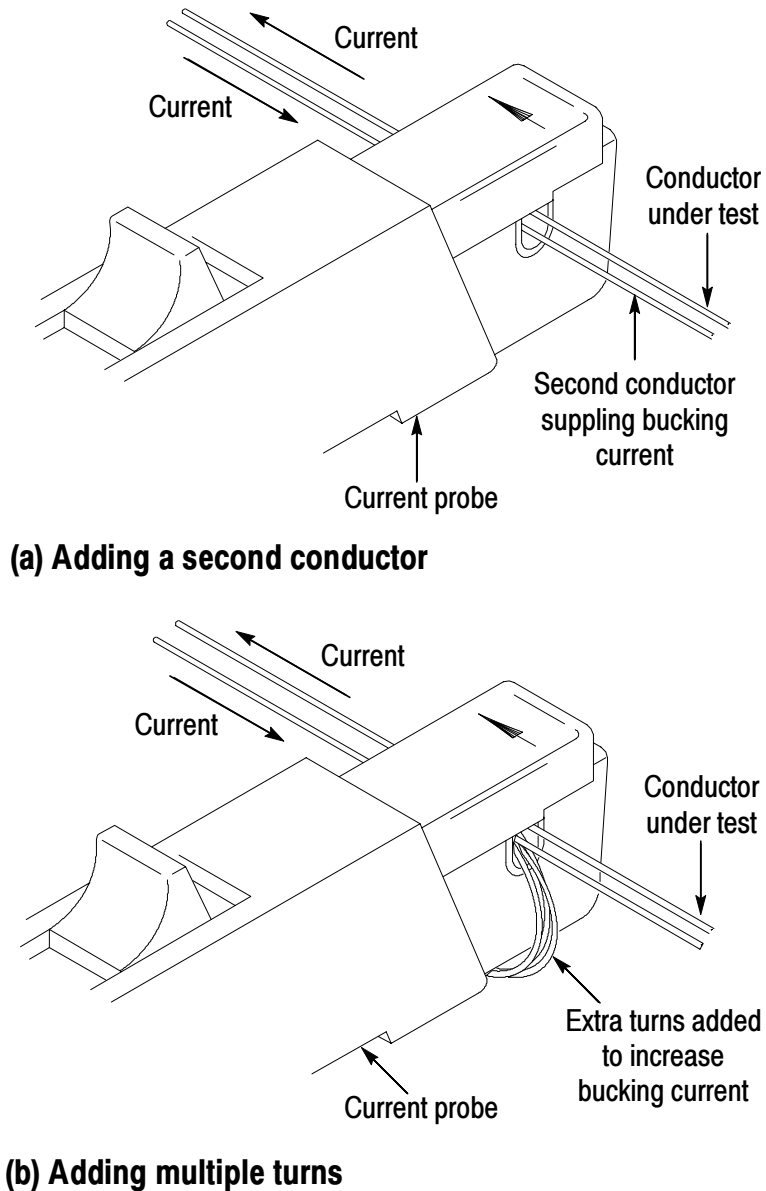

Figure 6: Increasing the DC Measurement Range

Increasing Measurement Sensitivity

If you are measuring DC or low-frequency AC signals of very small amplitudes, you can increase measurement sensitivity of your Current Probe by winding several turns of the conductor under test around the probe as shown in Figure 7. The signal is multiplied by the number of turns around the probe.

When viewing the signal on the oscilloscope screen, divide the displayed amplitude by the number of turns to obtain the actual current value. For example, if a conductor is wrapped around the probe five times and the oscilloscope shows a reading of 50 mA DC, the actual current flow is 50 mA divided by 5, or 10 mA DC.

NOTE. *Winding multiple turns around the probe increases the insertion impedance of the probe which can affect the accuracy of your measurements and the circuit under test. For graphs of insertion impedance, refer to figures 15 and 17 on page 23.*

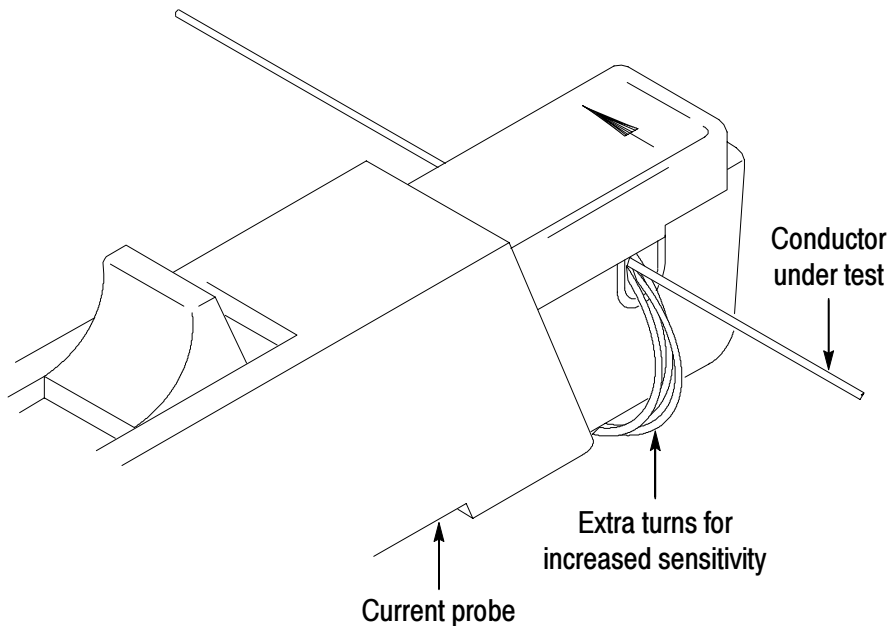

Figure 7: Increasing Probe Sensitivity

Reference

This section describes extended measurement applications of the TCP202 Current Probes:

- Power Measurements
- Inductance Measurements
- Continuity Test of Multiple-Conductor Cable
- Measuring Inductor Turns Count

Power Measurements

You can measure the instantaneous power delivered to the load of a two-wire circuit using a digital oscilloscope that allows you to multiply two channels.

1. Connect the output of a differential voltage probe (such as the P5205) to one channel and the output of the TCP202 Current Probe to the other channel of the oscilloscope.

NOTE. *For high-frequency measurements, the time (propagation) delays of both probes should match. (The P5205 and TCP202 probes, for example, have matching propagation delays.) You can also use the deskew function available on some TDS oscilloscopes to match the time delays.*

2. Connect the + input of the differential probe to the first terminal and - input to the second (reference) terminal.
3. Close and lock the current probe around the conductor of the first terminal with the arrow on the probe head pointing in the direction of the reference.
4. So that the voltage and current waveforms are phase-related, select only one channel as the trigger source and acquire the two waveforms.

5. After acquiring the current and voltage waveforms, set the two channels to multiple together. (On the TDS Series oscilloscopes that have this capability, select MORE→Change Math waveform definition→Dual Wfm Math→Set operator to *→OK Create Math Wfm.) The oscilloscope displays the power waveform.

Other functions on TDS oscilloscopes allow you to measure the average power for one cycle (Cycle Mean) or the average power for the entire record (Mean). Refer to the user manual of your oscilloscope for more information.

Inductance Measurements

You can use the current probe to measure the inductance of coils that have either a low-impedance or high-impedance pulse source of a known value.

Low-Impedance Pulse Sources

Figure 8 shows a measurement setup using a constant-voltage pulse generator of extremely low output impedance connected to an inductor that has low resistance. The inductor is connected across the output terminals of the pulse source and a constant voltage is maintained across the inductor. The current probe is clamped over one of the source leads and the current ramp is measured.

The inductance is effectively defined by the slope of the current ramp, shown in Figure 9, and is mathematically expressed by the following formula:

$$L = \frac{-E}{\frac{di}{dt}}$$

where L is the inductance in henries, E is the voltage of the pulse generator, dt is the change in time, and di is the change in current.

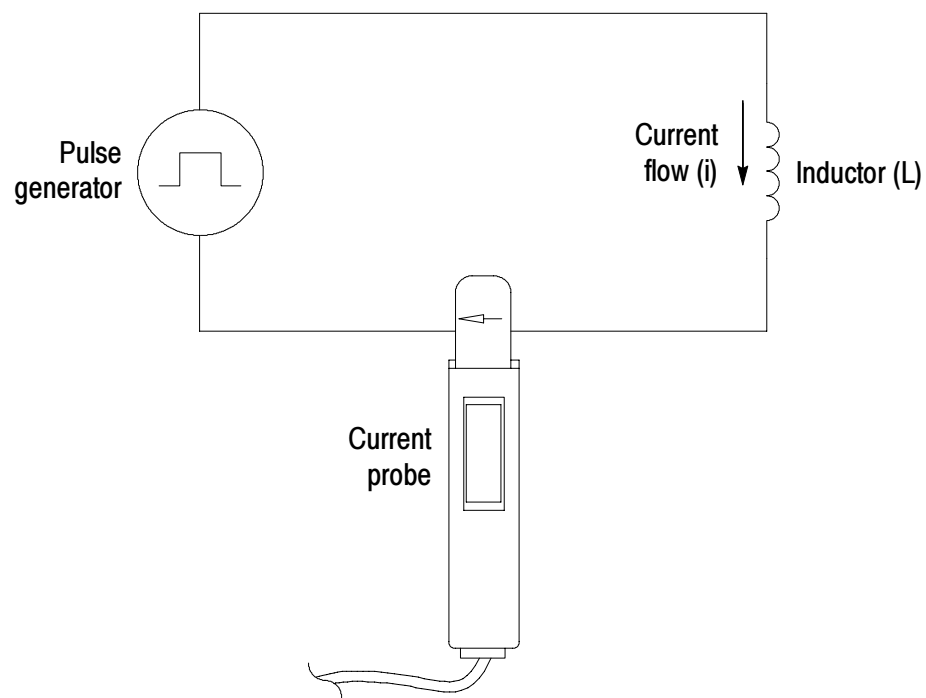

Figure 8: Measuring Inductance with a Low-Impedance Source

NOTE. *If the probe impedance is a significant part of the total circuit inductance, measurement accuracy will be affected. Refer to the probe specifications for probe insertion impedance.*

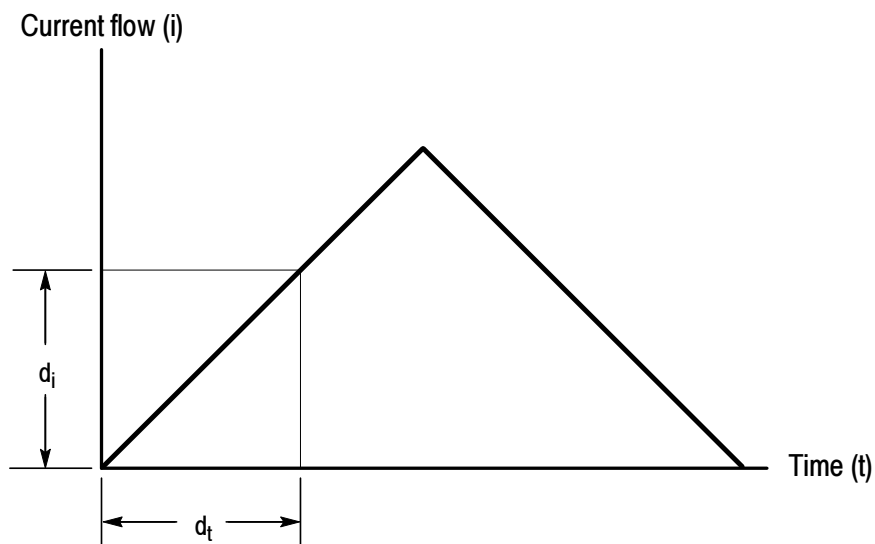

Figure 9: Linear Current versus Time Ramp

High-Impedance Pulse Sources

If the pulse source has a higher impedance of known resistance, such that the output voltage drops as the current increases, the inductance of a coil can be calculated by the time constant of the charge curve. Figure 10 shows the setup diagram, which is similar to the previous example. The current ramp represented in Figure 11 shows how the values for the inductance formula are obtained.

Use this formula to calculate the inductance based on the current measurement:

$$L = \tau R$$

where L is the inductance in henries, τ is the time required for the current to rise or fall 63.2% of the total current value, and R is the source resistance of the pulse generator.

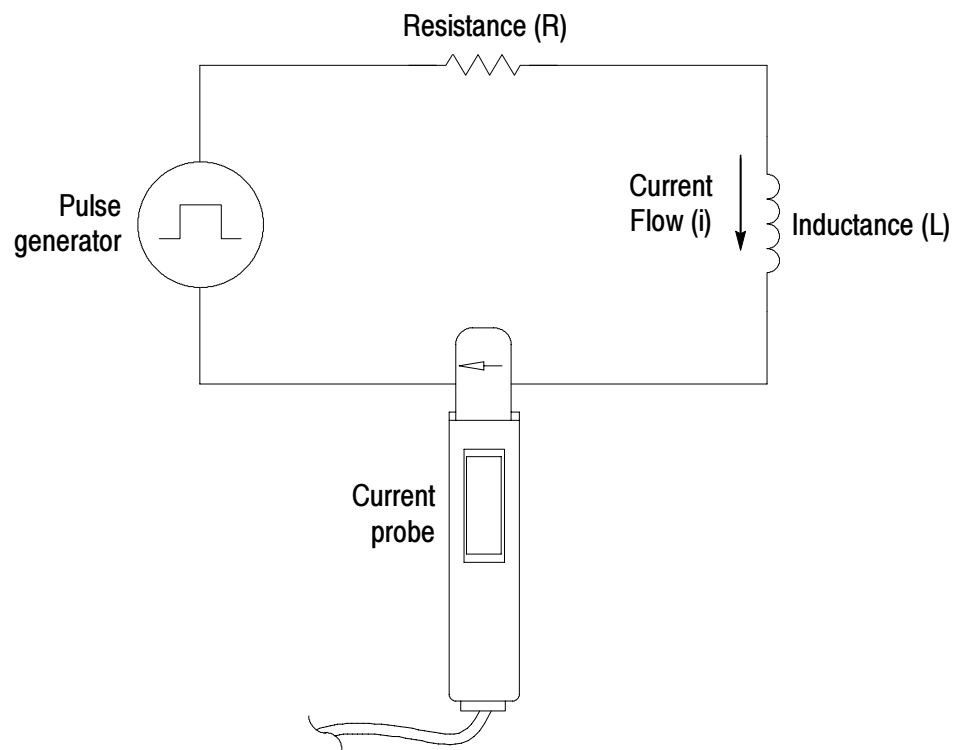

Figure 10: Measuring Inductance with a High-Impedance Source

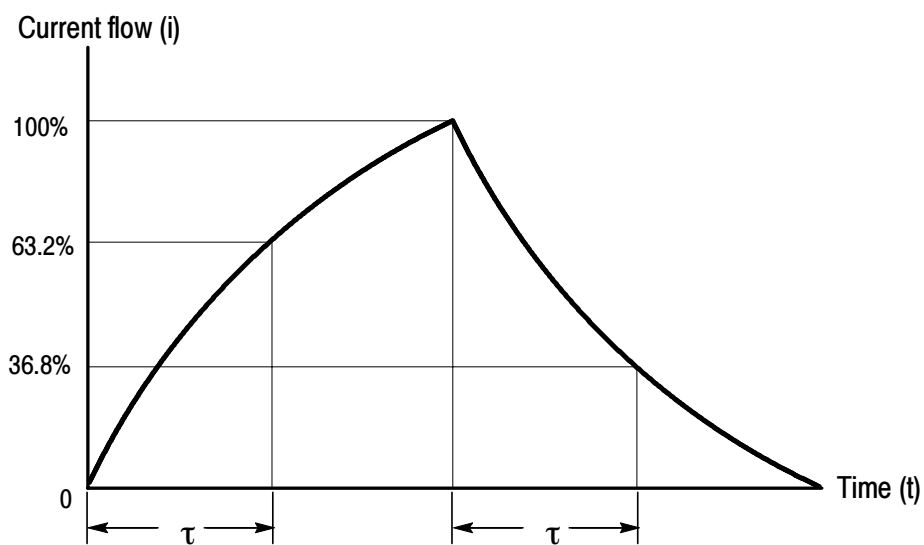

Figure 11: High-Impedance Source Current Ramp

Continuity Test of Multiple-Conductor Cable

You can test single conductors in a multiconductor cable. To check a conductor, clamp the current probe around the cable bundle and check for a specific, known current signal. If there is no current or the current is abnormally low, then the conductor has a continuity problem. If the current is abnormally high, then the conductor may have a short to ground.

Measuring Inductor Turns Count

To obtain an approximate turns count of an inductor, connect the inductor to a current limited source, as shown in Figure 12. Measure the input current on one of the inductor leads, then clamp the current probe around the inductor and note the current value. The number of turns is equal to the ratio of coil current to input current. The accuracy of this method is limited by the current measurement accuracy. The following method allows more precise turns measurement.

For a more precise turns count, you need a coil with a known number of turns to use as a reference. The measurement setup is similar to that previously described, except the reference coil and the test coil are inserted into the current probe so that the currents oppose each other (see Figure 13). You must observe the polarity of coil current to determine whether the test coil has more or fewer turns than the reference coil. The turns are calculated by using the formula:

$$N_2 = N_1 \times \frac{I_m}{I_I}$$

where N_2 is the number of turns in the test coil, N_1 is the number of turns in the reference coil, I_m is the measured coil current, and I_I is the input current.

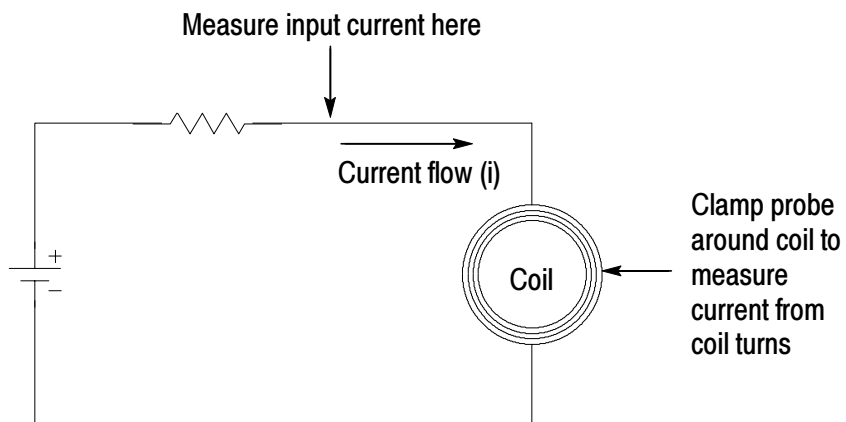

Figure 12: Measuring the Number of Turns in a Coil

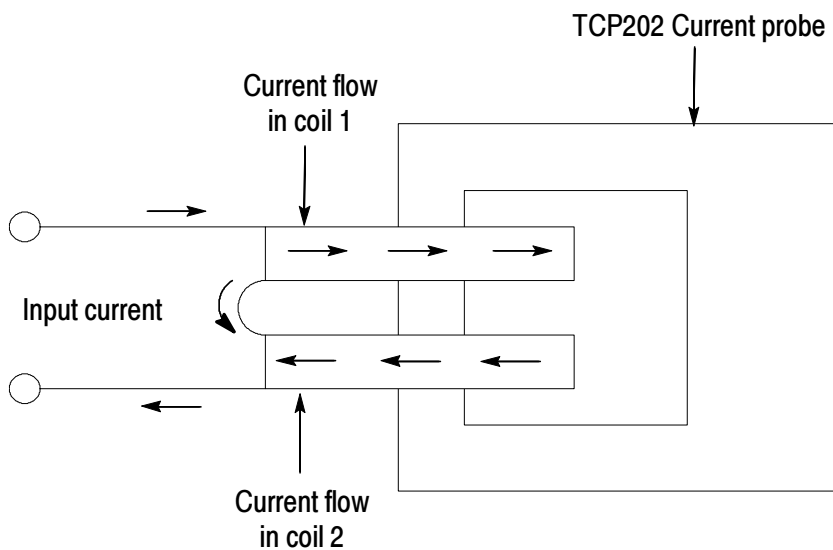

Figure 13: Turns Measurement Using Reference Coil

Specifications

The specifications in Tables 1 through 4 apply to a TCP202 Current Probe installed on a Tektronix TDS 520B Oscilloscope. The tables also list the specifications for the calibrator (page 50) that can be used on some TDS oscilloscopes to increase the DC accuracy.

When the probe is used with another oscilloscope, the oscilloscope must have a bandwidth of at least 200 MHz. Oscilloscopes without the TekProbe interface must use a Tektronix 1103 TekProbe Power Supply.

The probe must have a warm-up period of at least 20 minutes and be in an environment that does not exceed the limits described in Table 1.

Specifications for the TCP202 Current Probe fall into three categories: warranted, typical, and nominal characteristics.

Warranted Characteristics

Warranted characteristics (tables 1 and 2) describe guaranteed performance within tolerance limits or certain type-tested requirements. Warranted characteristics that have checks in the *Performance Verification and Adjustment* section appear in boldface type.

Table 1: Warranted Electrical Characteristics

DC Accuracy	$\pm 3\%$ (correctable to $\pm 1\%$ from 50 mA to 5 A and $\pm 2\%$ from 5 A to 15 A when used with calibrator on self-calibrating TDS series oscilloscopes)
Calibrator Resistance	42 Ω
Calibrator Amp-turns	0.500 Amp-turns
System Bandwidth	DC to 50 MHz (oscilloscope bandwidth ≥ 200 MHz)
System Rise Time	< 7 ns (oscilloscope rise time < 1.75 ns)

Table 1: Warranted Electrical Characteristics (Cont.)

Maximum DC and Low Frequency Current (See Figure 19)	15 A (DC + peak AC)
Maximum Peak Current (See Figure 19)	50 A with pulse width $\leq 10 \mu\text{s}$
Maximum Voltage on Uninsulated Wire	300 V (DC + peak AC), CAT I
Temperature	Operating: +5 to +50° C Nonoperating: -10 to +60° C
Humidity	Operating: tested at 90 to 95% RH, +30° to +50° C Nonoperating: tested at 90 to 95% RH, +30° to +60° C

Table 2: Certifications and Compliances

EC Declaration of Conformity	Meets intent of Low Voltage Directive 73/23/EEC for Product Safety. Compliance was demonstrated to the following specification as listed in the Official Journal of the European Communities: Low Voltage Directive 73/23/EEC: EN 61010-1 Safety requirements for electrical equipment for measurement, control, and laboratory use IEC 1010-2-032 Particular requirements for hand-held current clamps for electrical measurement and test
Certifications	Underwriters Laboratories certified to Standard UL3111-1 for Electrical and Electronic Measuring and Testing Equipment, CAN/CSA-C22.2 No. 1010.1, and IEC 1010-2-032

Table 2: Certifications and Compliances (cont.)

Overvoltage Category	Category:	Examples of Products in this Category:
	CAT II	Local-level mains, appliances, portable equipment
	CAT I	Signal levels in special equipment or parts of equipment, telecommunications, electronics
Pollution Degree 2	Do not operate in environments where conductive pollutants may be present.	

Typical Characteristics

Typical characteristics (Table 3) describe typical but not guaranteed performance.

Table 3: Typical Electrical Characteristics

Frequency Derating	See Figure 14
System Noise	< 2.5 mA _{RMS} , bandwidth of measurement device limited to 20 MHz (At higher bandwidths, the noise is a function of the oscilloscope front end noise)
System Aberrations	10% p-p
Insertion Impedance	Phase angle: See figures 16 and 18 Magnitude: See figures 15 and 17
Time (Propagation) Delay	17 ns
Amp-second Product (See Figure 19)	500 μAs

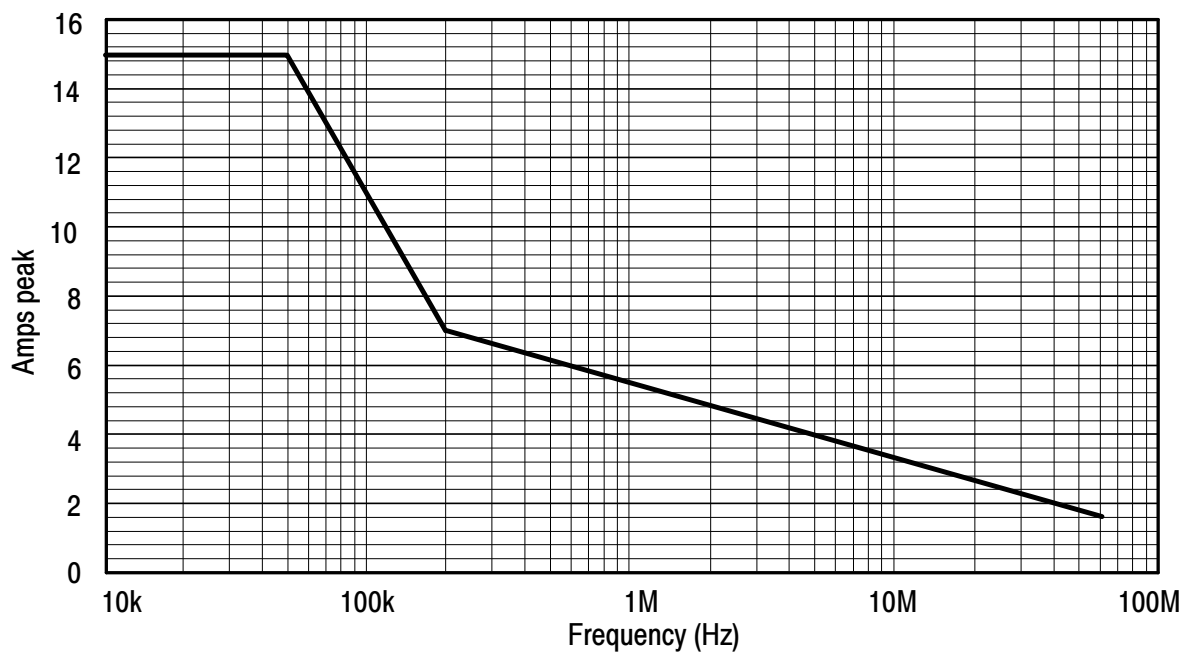

Figure 14: Frequency Derating

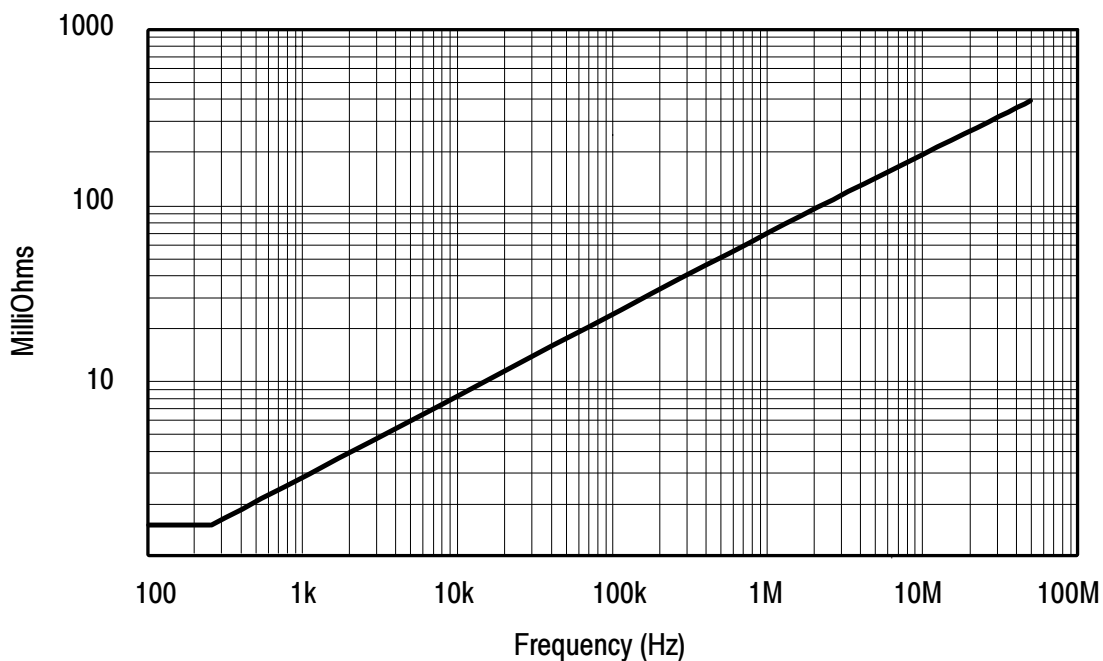

Figure 15: Insertion Impedance - Magnitude - Single Conductor

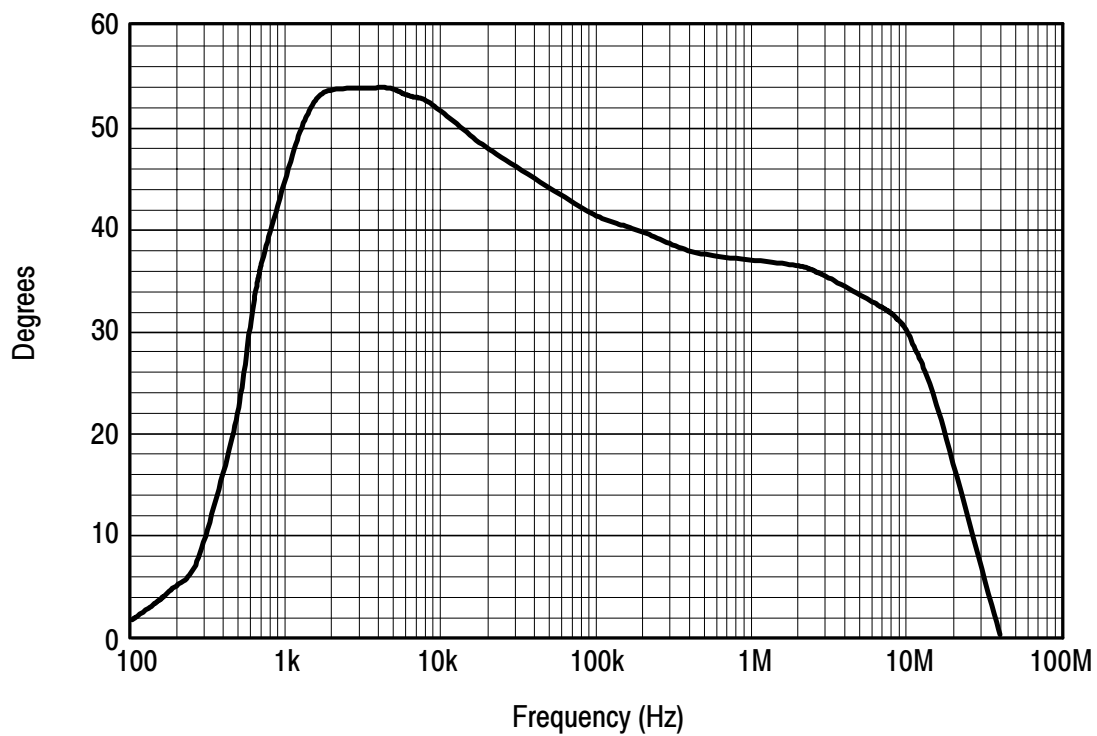

Figure 16: Insertion Impedance - Phase Angle - Single Conductor

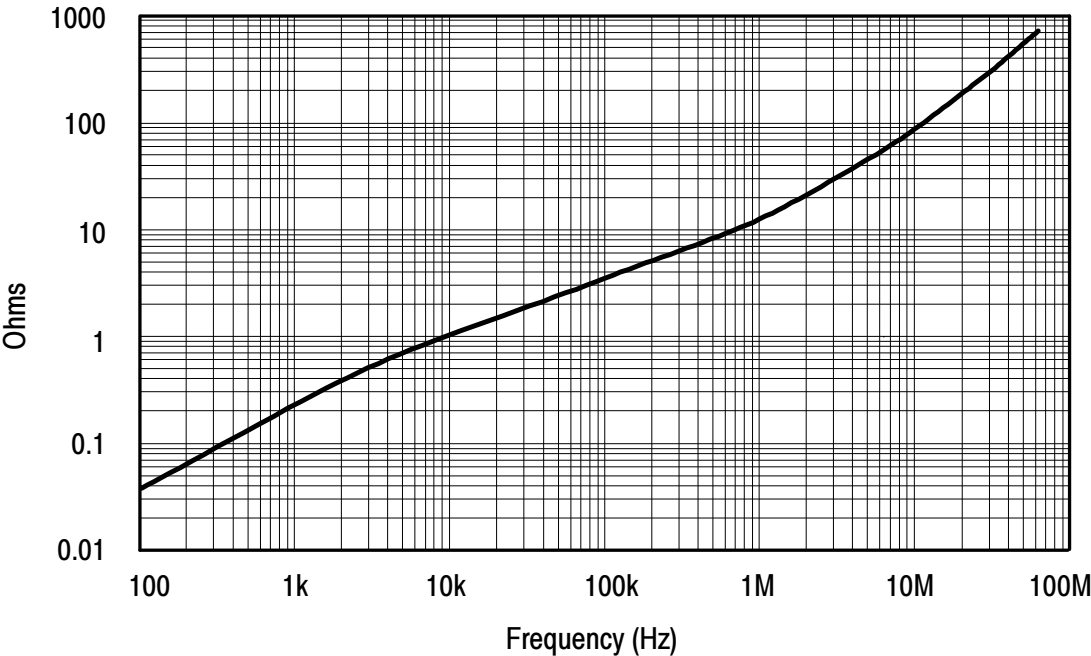

Figure 17: Insertion Impedance - Magnitude - 10-Turn #24 AWG Primary

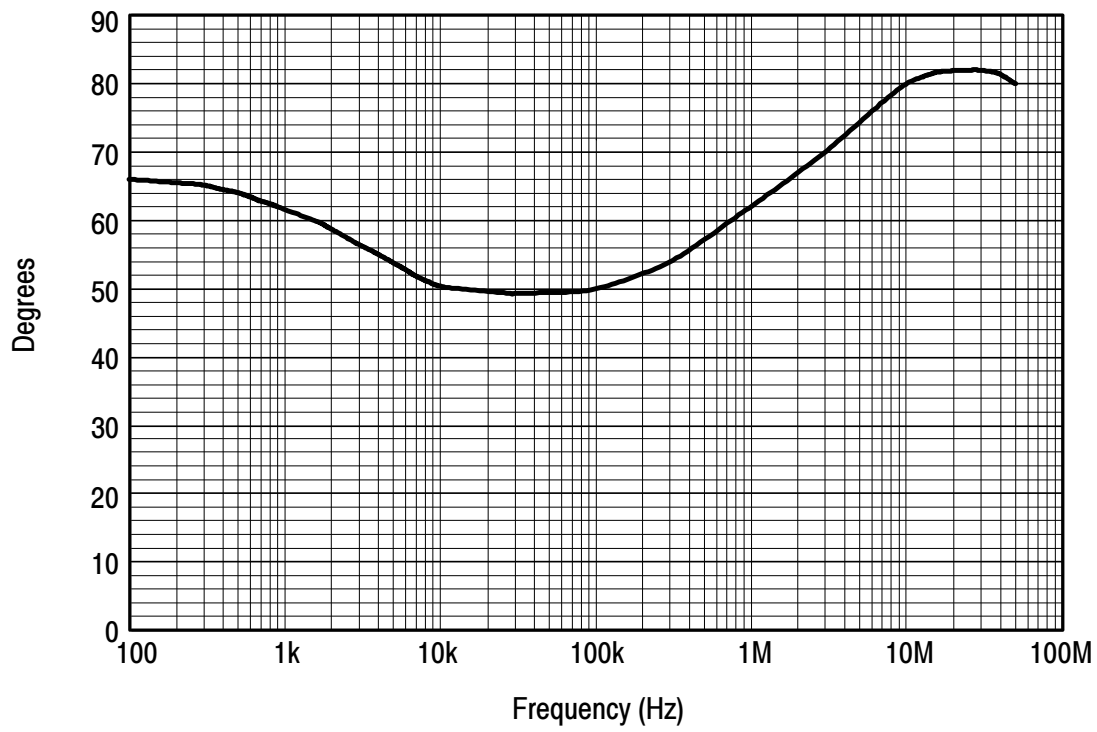

Figure 18: Insertion Impedance - Phase Angle - 10-Turn #24 AWG Primary

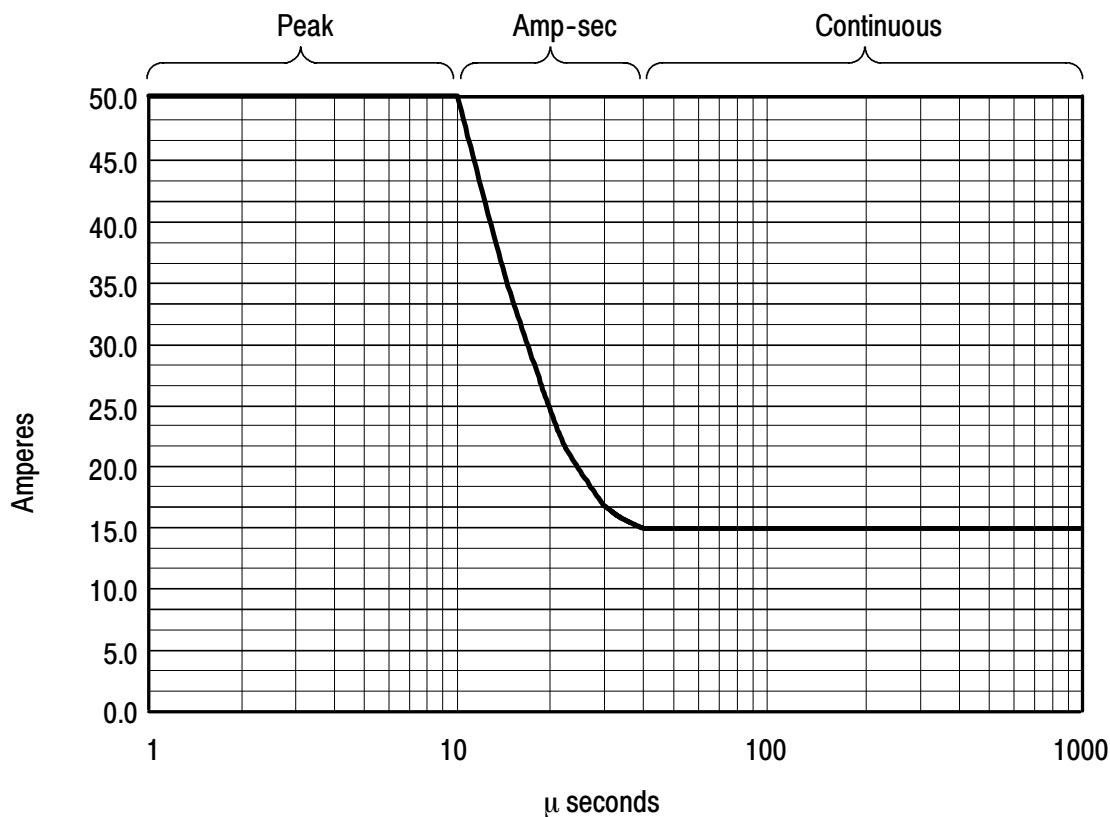

Figure 19: Current Ratings

Nominal Characteristics

Nominal characteristics (Table 4) describe guaranteed traits, but the traits do not have tolerance limits.

Table 4: Nominal Characteristics

Current Transfer Ratio	0.1 Volt/Amp into 50 Ω
Jaw Opening	3.8 mm (0.15 in) diameter
Dimensions, Probe Head	Length: 200 mm (7.76 in) Width: 16 mm (0.62 in) Height: 32 mm (1.25 in)
Unit Weight (probe only)	0.19 kg (0.44 lbs)
Cable Length	2.16 m (85 in)

Table 4: Nominal Characteristics (Cont.)

Maximum Clamp-on Conductor Size	7 AWG, bare conductor
Calibrator Turns	42

Maintenance

This section explains how to access and maintain components of the probe. Only qualified service personnel should perform the disassembly procedures in this section.

Cleaning the Probe Head

The jaw of the probe head consists of a slider and current sensing transformer. When the jaw is closed, the core of the transformer is electrically complete and the probe head can sense current flowing through a conductor in the jaw. If the DC accuracy is not within specified limits, it may be due to an accumulation of debris on the mating surfaces of the core.

To partially clean the mating surfaces of the core, open the jaw and clean the exposed surfaces with a cotton swap dampened with isopropyl alcohol or ethyl alcohol (fotocol or ethanol). In most cases this should be enough to restore the accuracy of the probe.

To fully clean all mating surfaces of the core you must disassemble the probe head. Refer to page 34.

Do not lubricate the mating surfaces of the core. Any lubricant between the core pieces should be removed with a recommended solvent.

To clean the probe body, use a soft cloth dampened in a solution of mild detergent and water.

Do not use chemicals containing benzine, benzene, toluene, xylene, acetone, or similar solvents.

Do not use a petroleum based lubricant on the plastic. If the plastic slide assembly requires lubrication, use a silicone based grease sparingly.

Do not immerse the probe in liquids or use abrasive cleaners.

Servicing the Compensation Box

Some components of the compensation box can be serviced. These components include the TekProbe interface pins, probe collar, compensation box covers, and the gain adjustment.

Replacing TekProbe Interface Pins

TekProbe interface pins can stick and fail to make contact after time. Periodically check each of the interface pins. Replace any pin that fails to move freely and fully extend.

To remove a TekProbe interface pin, firmly grasp the pointed tip with pliers and pull the pin out of the connector. See Figure 20.

No tools are required to install a replacement pin. Insert a new pin into the connector socket as far as possible using finger pressure. If necessary, seat the pin into the connector by pressing the tip of the pin gently but firmly against a hard surface.

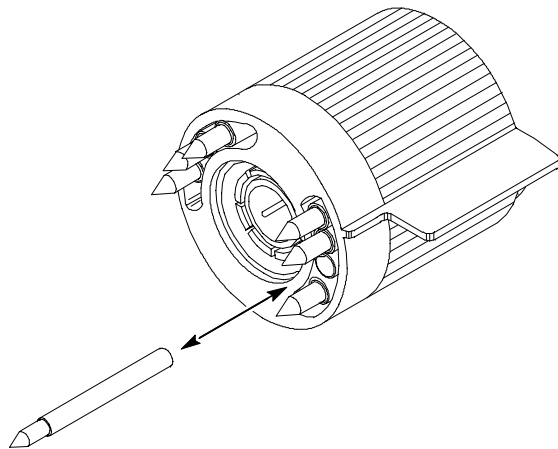

Figure 20: Replacing TekProbe Interface Pins

Removing and Replacing the TekProbe Interface Collar

To remove the TekProbe interface collar, firmly grasp the compensation box body with one hand and the TekProbe interface collar with the other hand. Firmly pull the interface collar off.

To replace the collar, note the pin configuration on the compensation box and their holes in the interface collar. The group of three pins fit through the smaller of the two holes in the interface collar. See Figure 21.

Align the tab to the slot and gently press the two pieces together.

Once installed, the TekProbe collar should rotate freely to lock and unlock.

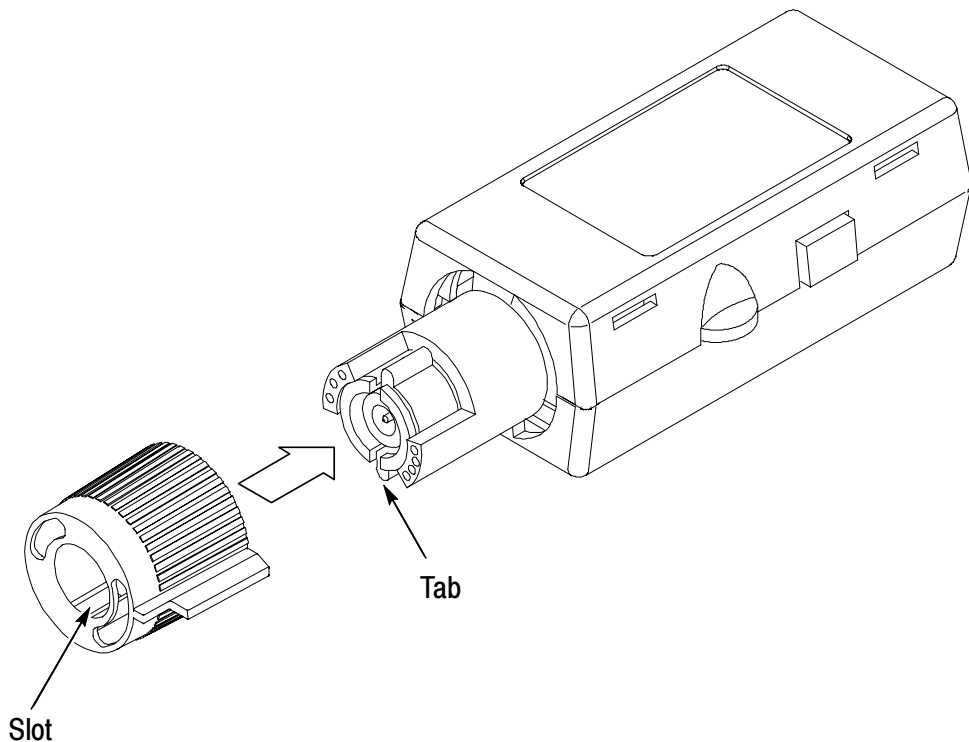

Figure 21: Replacing the TekProbe collar

Removing the Compensation Box Covers



CAUTION. To prevent damage to internal components by means of electrostatic discharge (ESD), wear a grounded anti-static wrist strap.

To open the compensation box, follow these steps:

1. Press the optional release tool pins into the compensation box cover catches and gently lift the cover off a small distance. Refer to Figure 22.
2. Hold the open edge apart, and use the tool to open the other side of the compensation box.
3. With both sides of the box open, gently separate the two halves of the compensation box.

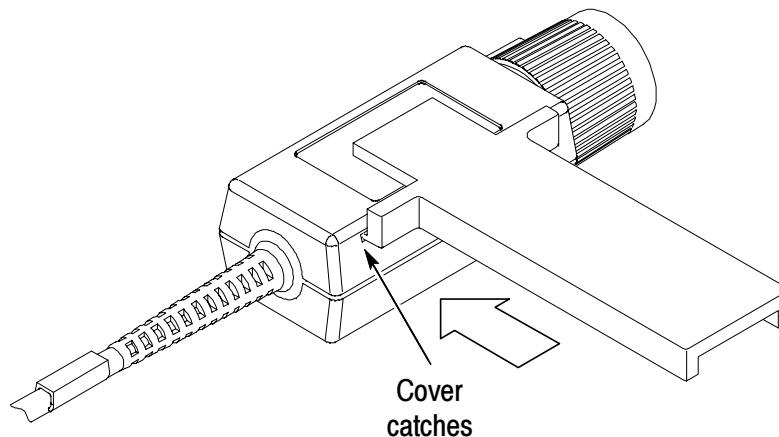

Figure 22: Removing the Compensation Box Covers

Accessing the Gain Adjustment

1. Open the compensation box with the release tool. Remove the top cover.
2. Carefully lift the back edge of the circuit board to access the gain adjustment. Refer to Figure 23.

3. Connect the output of the probe to the oscilloscope.
4. Adjust the probe using the setup for the DC accuracy test as described on page 41 or use a $0.5 A_{p-p}$ signal that is accurate to within $\pm 2\%$ and set the DC gain to exactly 5 divisions.

NOTE. *The gain of the probe must be within $\pm 2\%$ for the compensation routine to work properly.*

5. After adjusting the probe, disconnect the probe from the setup.

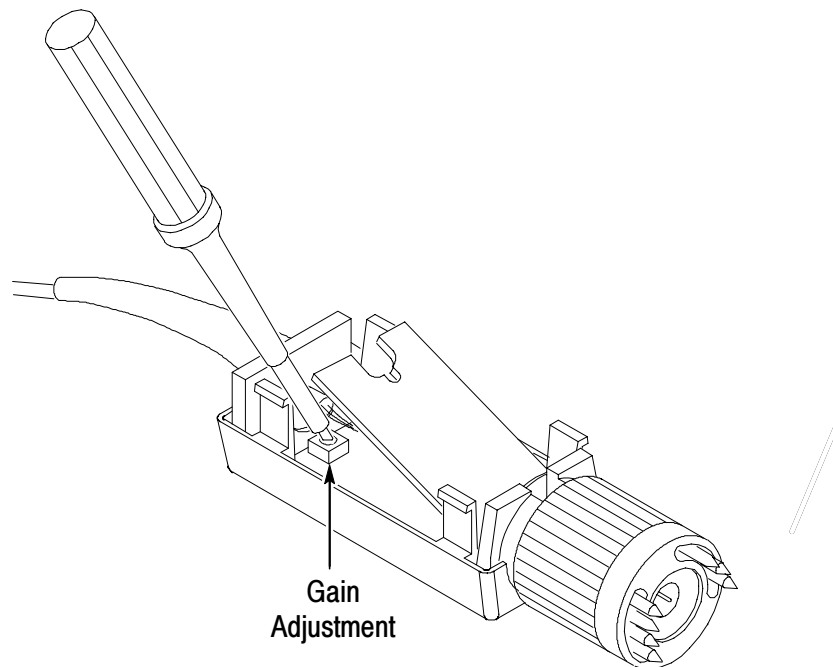

Figure 23: Accessing the Gain Adjustment

Replacing the Compensation Box Covers

To replace the covers, follow these steps:

1. Align the TekProbe interface and the strain relief notches with the tabs on the cover. Refer to Figure 24.
2. Press the catches of the cover in and lower the cover.

3. Slide the tab into the notch.
4. Firmly press the pieces together until the cover catches snap into place.

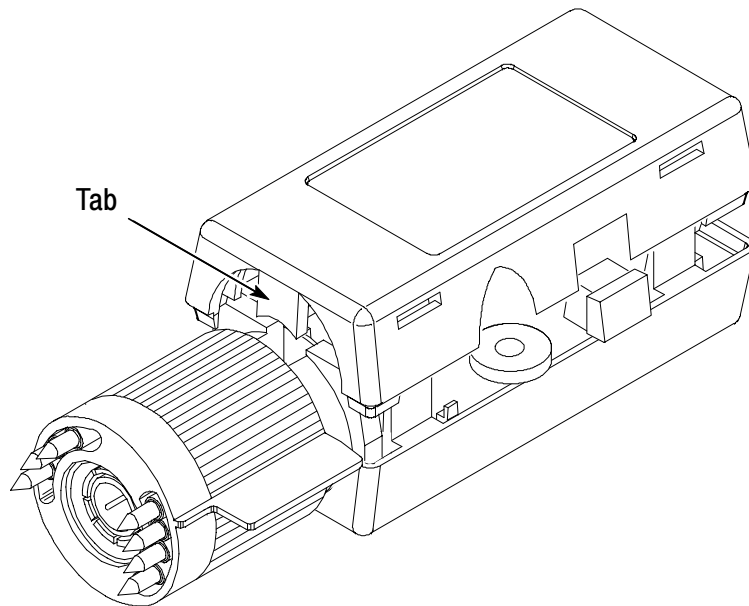

Figure 24: Replacing the Compensation Box Cover

Probe Head Disassembly



WARNING. *Probe disassembly should only be performed by qualified service personnel.*

1. Remove the two screws from the bottom of the probe and pull the strain relief boot back as shown in Figure 25.

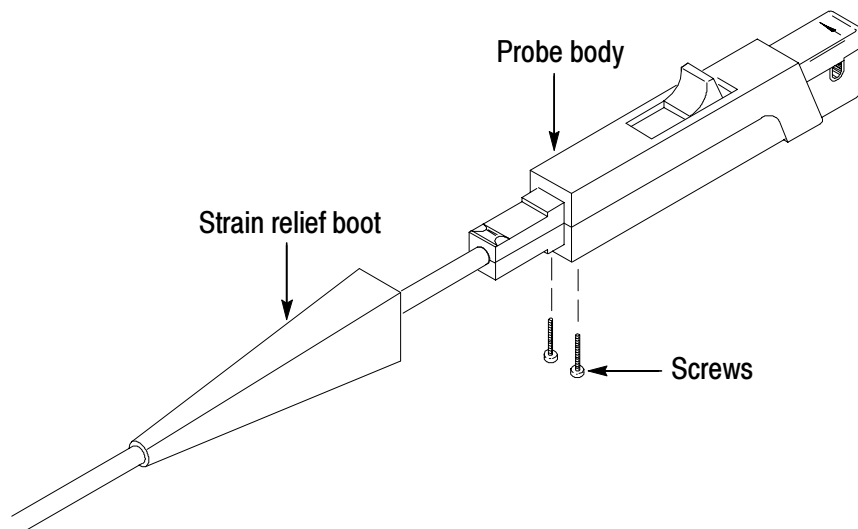

Figure 25: Removing the Strain Relief Boot

2. Move the probe slide assembly to the open position.

NOTE. *The probe slide contains a tiny metal ball. In step 3, be careful not to lose the ball by accidentally letting it fall out.*

3. Hold the probe in a top-up horizontal position and slide the top half of the probe body off as shown in Figure 26.
4. Remove the metal ball.
5. Turn the probe upside down, push the slide back slightly, and remove the slide (see Figure 27).

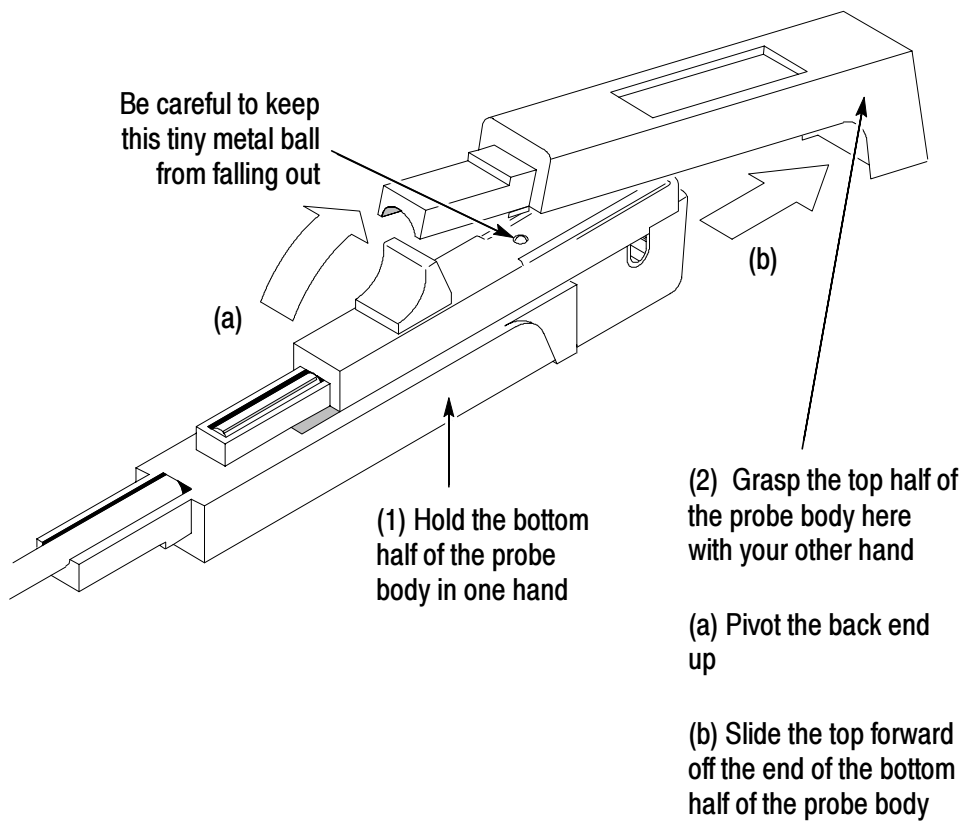

Figure 26: Removing the Top Half of the Probe

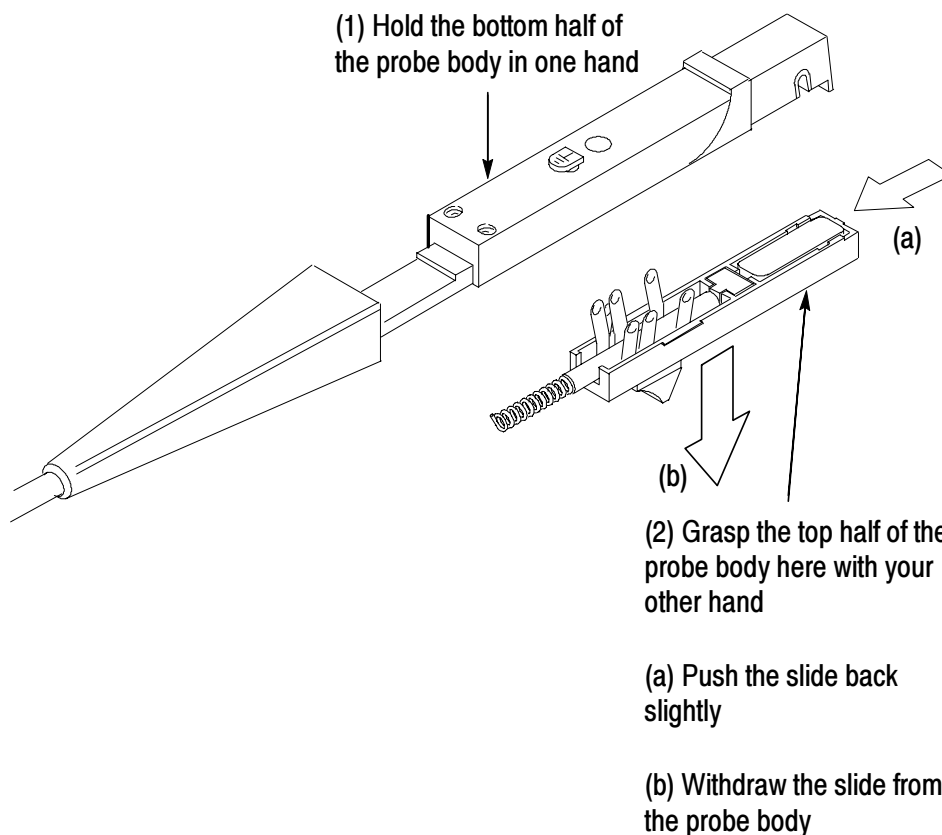

Figure 27: Removing the Probe Slide

NOTE. *The circuit board may be soldered to a ground post attached to the body half. If necessary, carefully desolder the connection before attempting to remove the circuit board.*

6. If you want to replace the current transformer, lift the transformer out of the probe as shown in Figure 28, and pull it out of the circuit board socket. The circuit board may be removed by lifting out the strain relief and the circuit board from the body half.

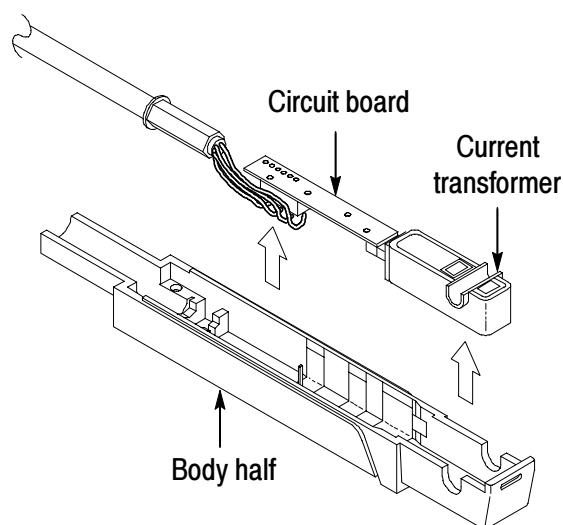

Figure 28: Removing the Current Transformer

7. Before reassembling the probe, be sure that the gap between the stationary and moveable core pieces is clean. If necessary, use Lubriplate or a similar cleaning agent to clean the pieces. If necessary, clean the contacts of the slide switch.
8. Should the plastic slide assembly require lubrication, sparingly apply silicone-based grease to the parts.
9. Probe reassembly is the reverse of steps 1 through 8.

NOTE. Exercise care when fitting the slide back into the probe body; aligning the switch contacts can require patience.

Obtaining Replacement Parts

Replacement parts may be obtained through your local Tektronix field office or representative. Refer to *Replaceable Parts* on page 44 for more information.

Preparation for Shipment

If you must ship your Tektronix product, please use the original packaging if possible. If the original packaging is unfit for use or not available, use the following packaging guidelines:

1. Use a corrugated cardboard shipping carton having inside dimensions at least one inch greater than the probe dimensions. The box should have a carton test strength of at least 200 pounds.
2. Put the probe into a plastic bag or wrap to protect it from dampness.
3. Place the probe into the box and stabilize it with light packing material.
4. Seal the carton with shipping tape.

Performance Verification and Adjustment

The procedures in this section allow you to demonstrate that the TCP202 Current Probe and the optional calibrator meet the specified levels of performance and to adjust them if necessary.

Test Procedure Conditions

These procedures are valid only under the following conditions:

- The system has been calibrated at an ambient temperature between +20° C and +30° C
- The system is operating in an environment whose limits are described in Table 1 on page 21
- The system, including probe, has had a warm-up period of at least 20 minutes
- The probe degauss and balance routine has been performed after the 20-minute warm-up period

Equipment Required

The following procedure verifies the warranted electrical characteristics of the TCP202 Current Probe. Table 5 itemizes the equipment required, provides an example or part number of the equipment, and explains the purpose of the equipment.

NOTE. *These procedures assume that you are using an oscilloscope that automatically displays the correct amperes/division. If not, you must take the scale factor of the probe into account when setting the volts/division on the oscilloscope. See page 3 for more information.*

Table 5: List of Equipment Required

Description	Minimum Requirements	Example or Part Number	Purpose
Test oscilloscope	Bandwidth: ≥ 200 MHz TekProbe interface vertical accuracy: $\leq 1.5\%$	TDS 520B	Display probe output
Calibration generator	Amplitude accuracy: $\leq 0.25\%$ Rise time: ≤ 3 ns	Wavetek 9100 with oscilloscope option	Check probe DC accuracy, band- width, and rise time
BNC adapter	BNC-female-to-dual banana	103-0090-00	Interconnection, current loop and generator
Current loop, 50Ω	$50 \Omega \pm 0.5\%$, BNC male	015-0601-50 or 067-0559-00	Bandwidth and rise time checks
Current loop, 0Ω	18 AWG insulated wire, 8 cm (3 in) long	—	DC Accuracy check
Precision ohmmeter	0.02% accuracy with sense inputs (4 terminals)	Fluke 8840A	Check and adjust input resistance of optional calibrator

DC Accuracy

1. Connect a zero-ohm current loop to the output connectors of the calibration generator.
2. Set the calibration generator for a 1 A, DC output.
3. Set the amperes/division on the oscilloscope to 0.2 A with the display at a zero reference point at least two divisions below center screen.
4. Clamp the jaw of the probe head around the current loop.
5. Check that the DC accuracy is $\pm 3\%$ (4.85 to 5.15 divisions).
6. Disconnect the setup.

For higher accuracy, refer to page 4 and perform the probe compensation routine using the optional calibrator, then verify that the DC accuracy is $\pm 1\%$ (4.95 to 5.05 divisions).

NOTE. *For the compensation routine to work properly, the DC accuracy of the probe must be at least $\pm 2\%$ before you begin. If the probe fails the compensation routine, refer to page 29 for information on cleaning the probe head and page 32 for information on accessing the gain adjustment.*

Bandwidth

1. Connect a 50 Ω current loop to the output connector of the calibration generator.
2. Clamp the jaw of the current probe around the current loop.
3. Set the amperes/division on the oscilloscope to 10 mA and time/division to 20 μ s. (If you are using a digitizing oscilloscope, set the acquisition mode to Average and the number of samples to 16.)
4. Set the calibration generator to 50 kHz and the amplitude to display 6 divisions on screen.
5. Set the generator to 50 MHz and the oscilloscope to 5 ns/division.
6. Check for ≥ 4.2 divisions peak to peak.
7. Disconnect the setup.

Rise Time

1. Connect a 50 Ω current loop to the 50 Ω fast-rise output of the calibration generator.
2. Clamp the jaw of the current probe around the current loop.

3. Set the amperes/division on the oscilloscope to 10 mA and time/division to 5 ns. (If you are using a digitizing oscilloscope, set the acquisition mode to Average and the number of samples to 16.)
4. Set the fast-rise amplitude to display 2 divisions on screen.
5. Check that the rise time is ≤ 7 ns.
6. Disconnect the setup.

Calibrator Accuracy (Optional)

1. Connect the sense and input probe tips of the precision ohmmeter across the two input terminals of the calibrator. (The probe tips of the sense leads and input leads must contact at the same two points.)
2. Check that the input resistance of the calibrator measures 42.00 ohms.
3. If the reading is not exact, insert a flat-blade adjustment tool into the hole in the left side of the calibrator and adjust the resistance to a value of 42.00 ohms.
4. Disconnect the setup.

Replaceable Parts

This section contains a list of the replaceable modules for the TCP202 Current Probe. Use this list to identify and order replacement parts.

Parts Ordering Information

Replacement parts are available through your local Tektronix field office or representative.

Changes to Tektronix instruments are sometimes made to accommodate improved components as they become available and to give you the benefit of the latest circuit improvements. Therefore, when ordering parts, it is important to include the following information in your order:

- Part number
- Instrument type or model number
- Instrument serial number
- Instrument modification number, if applicable

If you order a part that has been replaced with a different or improved part, your local Tektronix field office or representative will contact you concerning any change in part number.

Change information, if any, is located at the rear of this manual.

Using the Replaceable Parts List

This section contains a list of the mechanical and/or electrical components that are replaceable for the TCP202 Current Probe. Use this list to identify and order replacement parts. Table 6 describes each column in the parts list.

Table 6: Parts List Column Descriptions

Column	Column Name	Description
1	Figure & Index Number	Items in this section are referenced by figure and index numbers to the exploded view illustrations that follow.
2	Tektronix Part Number	Use this part number when ordering replacement parts from Tektronix.
3 and 4	Serial Number	Column three indicates the serial number at which the part was first effective. Column four indicates the serial number at which the part was discontinued. No entries indicates the part is good for all serial numbers.
5	Qty	This indicates the quantity of parts used.
6	Name & Description	An item name is separated from the description by a colon (:). Because of space limitations, an item name may sometimes appear as incomplete. Use the U.S. Federal Catalog handbook H6-1 for further item name identification.
7	Mfr. Code	This indicates the code of the actual manufacturer of the part.
8	Mfr. Part Number	This indicates the actual manufacturer or vendor part number.

Abbreviations

Abbreviations conform to American National Standard ANSI Y1.1-1972.

Mfr. Code to Manufacturer Cross Index

The table titled Manufacturers Cross Index shows codes, names, and addresses of manufacturers or vendors of components listed in the parts list.

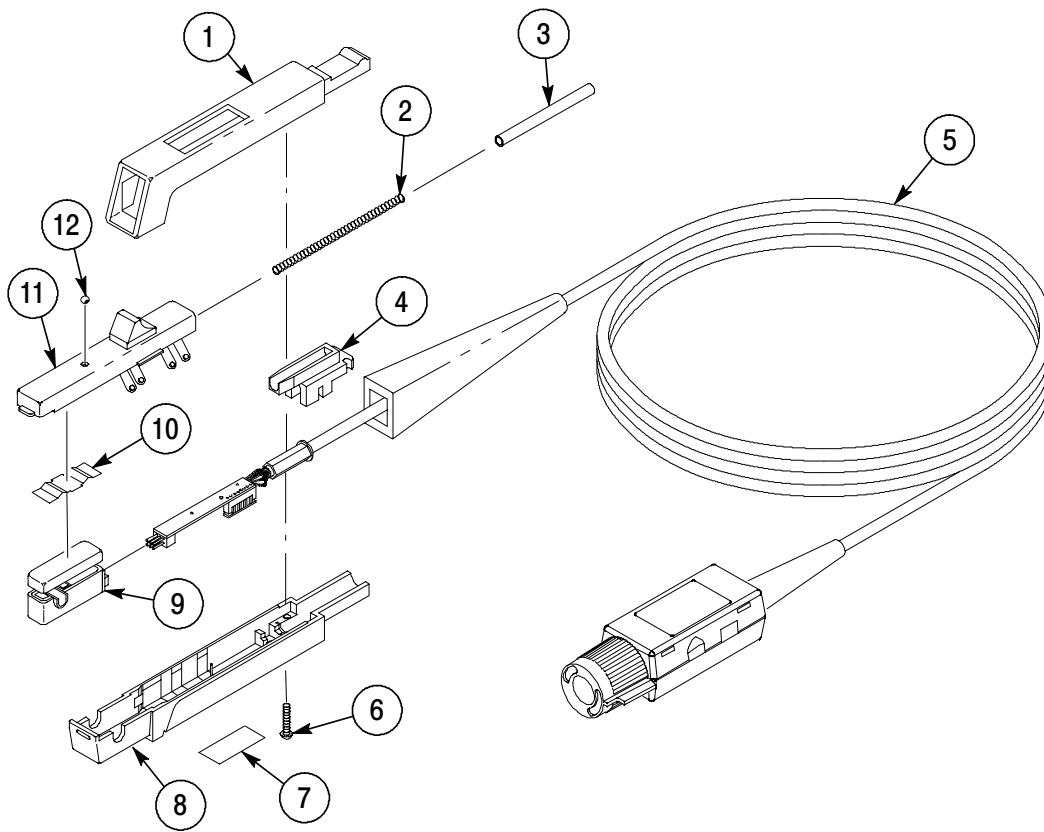

Figure 29: TCP202 and Replaceable Accessories

TCP202 Replaceable Parts and Accessories

Fig. & Index Number	Tektronix Part Number	Serial No. Effective	Serial No. Discont'd	Qty	Name & Description	Mfr. Code	Mfr. Part Number
29-				1	PROBE, CURRENT: TCP202		
-1	204-0288-03			1	BODY HALF,PROBE:UPPER	80009	204-0288-03
-2	214-0835-00			1	SPRING,HLCPS:0.127 OD X 2.65 L,SST	91260	ORDER BY DESCRIPTION
-3	214-0849-00			1	RTNR RETURN SPR:BRS CD PL	80009	214-0849-00
-4	352-0106-00			1	HOLDER,SPR RTNR:DELRIIN	TK2565	352-0106-00
-5	650-3463-00			1	BD/CABLE ASSY:CABLE W/TCP202 PROBE CIRCUIT BOARD	80009	650-3463-00
-6	213-0087-00			2	SCREW,TPG,TC:2-32 X 0.5,TYPE BT,PANHEAD,STEEL,CADIUM PLATED,POZIDRIVE	3M099	ORDER BY DESCRIPTION
-7	334-9171-00			1	MARKER, ID:PROBE ID,TCP202	0KB05	334-9171-00
-8	204-0714-06			1	BODY,HALF:LOWER BODY HALF W/CONTACTS	80009	204-0714-06
-9	120-1984-00			1	XFMR SUBASSY:UPPER & LOWER TRANSFORMER	80009	120-1984-00
-10	214-0854-00			1	CONTACT,ELEC:UPPER SHELF,CU BE	TK1947	214-0854-00
-11	351-0121-01			1	CONT ASSY,ELEC:PROBE SLIDE ASSY	80009	351-0121-01
-12	214-0997-00			1	BALL, BEARING:0.094,SST	05469	ORDER BY DESCRIPTION
	070-9542-XX			1	MANUAL,TECH:INSTRUCTIONS,TCP202	TK2548	070-9542-XX
	070-9543-XX			1	MANUAL,TECH:REFERENCE,TCP202	TK2548	070-9543-XX

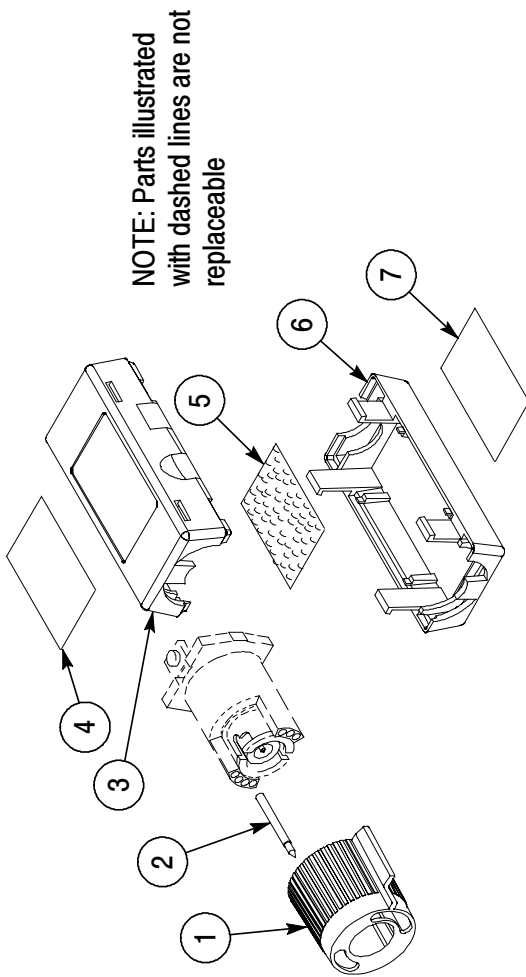

Figure 30: Replaceable Parts - Compensation Box

Replaceable Parts - Compensation Box

Fig. & Index Number	Tektronix Part Number	Serial No. Effective	Serial No. Discont'd	Qty	Name & Description	Mfr. Code	Mfr. Part Number
30-1	205-0191-00			1	SHELL,ELEC CONN:BNC,ABS,DOVE GRAY	80009	205-0191-00
-2	131-3627-01			1	CONTACT,ELEC:GOLD PLATED TIP	18359	P-6158-1
-3	206-0429-06			1	COMP BOX HALF:TOP	TK2565	206-0429-06

Replaceable Parts - Compensation Box (Cont.)

Fig. & Index Number	Tektronix Part Number	Serial No. Effective	Serial No. Discont'd	Qty	Name & Description	Mfr. Code	Mfr. Part Number
-4	334-9139-00			1	MARKER,IDENT:FRONT IDENTIFICATION LABEL,TCP202	0KB05	334-9139-00
-5	348-1487-00			2	CUSHION:FOAM CUSHION,30 PPI POLY FILTER FOAM,0.005 THK ACRYLIC ADHESIVE,1 SIDE,0.850 X 0	80009	348-1487-00
-6	206-0430-00			1	COMP BOX:COVER,BOTTOM HALF	80009	206-0430-00
-7	334-9140-00			1	MARKER,IDENT:BACK IDENTIFICATION LABEL,GE LEXAN,POLY,TCP202,	0KB05	334-9140-00

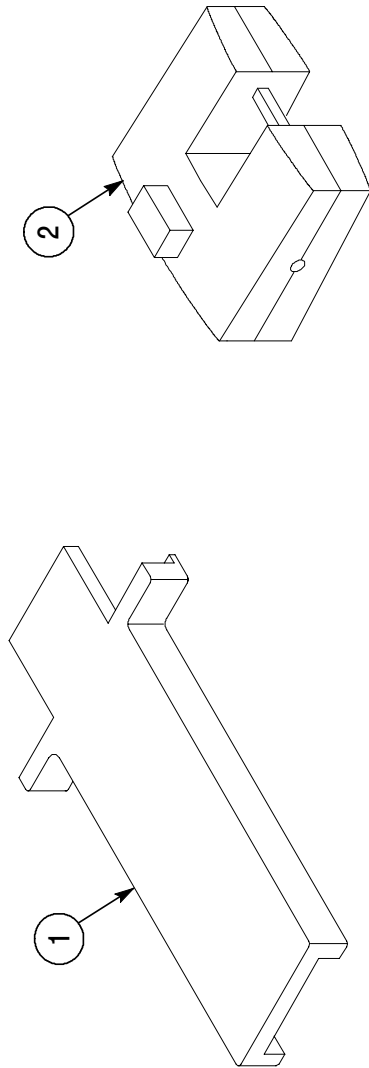

Figure 31: TCP202 Optional Accessories

Optional Accessories

Fig. & Index Number	Tektronix Part Number	Serial No. Effective	Serial No. Discont'd	Qty	Name & Description	Mfr. Code	Mfr. Part Number
31-1	003-1383-00			1	RLSE TOOL,COVER:COMP BOX,POLYCARBONATE	TK2565	003-1383-00
-2	015-0672-50			1	ADAPTER,CALIBRATOR: 50 TURN CURRENT LOOP, 50 OHM	80009	015-0672-50
	1103			1	TEKPROBE IF PS:W/OFFSET 2 CONN	80009	1103

Manufacturers Cross Index

Mfr. Code	Manufacturer	Address	City, State, Zip Code
05469	BEARINGS INC	3634 EUCLID PO BOX 6925	CLEVELAND, OH 44101
0KB05	NORTH STAR NAMEPLATE INC	5750 NE MOORE COURT	HILLSBORO, OR 97124-6474
18359	PYLON CO. INC.	51 NEWCOMB ST	ATTLEBORO, MA 02703-1403
3M099	PORTLAND SCREW COMPANY	6520 N BASIN AVE	PORTLAND, OR 97217
80009	TEKTRONIX INC	14150 SW KARL BRAUN DR PO BOX 500	BEAVERTON, OR 97077-0001
91260	CONNOR FORMED METAL PRODUCTS	1729 JUNCTION AVENUE	SAN JOSE, CA 95112
TK1947	NORTHWEST ETCH TECHNOLOGY	2601 S HOOD ST PO BOX 110610	TACOMA, WA 98411-0610
TK2548	XEROX CORPORATION	DIV OF XEROX CORPORATION 14181 SW MILLIKAN WAY	BEAVERTON, OR 97005
TK2565	VISION PLASTICS INC	26000 SW PARKWAY CENTER DRIVE	WILSONVILLE, OR 97070

